



1



How can you tell if system gain is properly set?

Do you measure it or do it by ear?
Whose ear?

2



Gain Structure Workshop: Defining & measuring proper gain structure

Jim Maltese, CTS-D, CTS-I, CQD, CQT
Dan Andrewson, CQT

3

ic26 What is gain structure?

“Gain structure is the strategic management of signal levels across every stage of the audio chain – from source to speakers – to maximize signal strength while minimizing noise and distortion”
– Radial Engineering Blog

The word 'infocomm' in a bold, sans-serif font, positioned in the bottom right corner of the slide.

4

ic26



infocomm

5

ic26

Stated another way...

We want to avoid that middle school talent show band vibe in our professional installations.

You know...like this one:

infocomm

6



7



8

ic26

Goal of Proper Gain Structure

- Deliver audio at the required listen levels
- Optimized signal to noise ratio
- Minimal total harmonic distortion



9

ic26

Listen Levels

What level should the system be by default?

What level should the system be able to handle?

What level do I design for?

Typical Sound Levels (dBA)

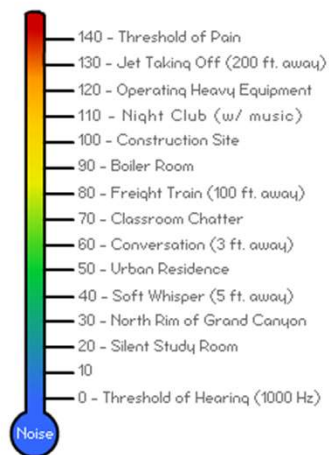

10



Listen Levels

What level should the system be by default?

- Listen Level
 - 65 dB SPL, a-weighted (65 dBA)?

What level should the system be able to handle?

- Headroom
 - 15 dB (emphatic talker/explosion)?

What level do I design for?

- Listen Level + Headroom
 - 65 dBA + 15 dB = 80 dB SPL
 - Design for worst case

11



How loud should the system be?

- “It depends” – Syn Aud Con
- Client preference
- Task
- Space
- No “right answer”, but should be defined, demonstrated, and approved



12

ic26

Signal to Noise Ratio

- How much separation there is between “the signal” and “the noise”
- Measured in dB
- Use Listen Level for “the signal”
 - It’s “harder” than the Headroom Level

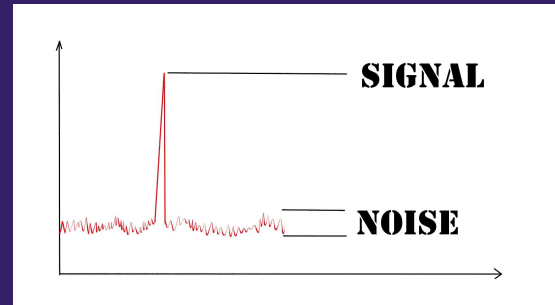

13

ic26

How much SNR do we need?

Enough to not hear the hum/hiss

Electronic \gg Acoustic SNR

If it's 20 dB more than the acoustic SNR, you won't hear the noise



14



Signal to Noise Demo

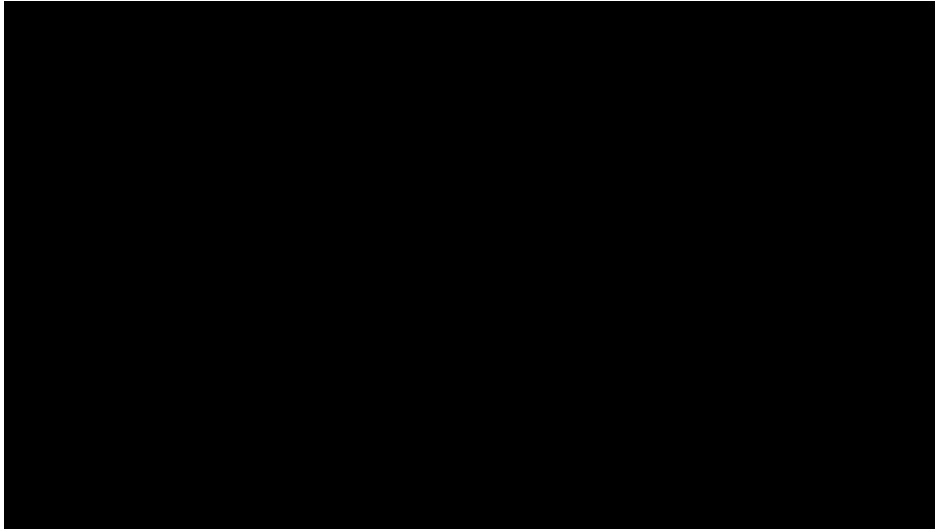

15



Acoustic SNR

- Avixa says at least 24 dB more than the ambient noise
- AQA V says at least 15 dB more than ambient noise
- The more the better!
- It can be challenging



16



Electronic vs. Acoustic SNR

Acoustic (dB-SPL, pressure)

- Signal Level
 - Listen Level
 - 65 dBA
- Noise Level
 - Ambient Noise Level
 - 35 dBA
- SNR
 - $65 \text{ dBA} - 35 \text{ dBA} = \mathbf{30 \text{ dB SNR}}$

Electronic (dBu, voltage)

- Signal Level
 - Listen Voltage at Amp
 - “10 dBu”?
- Noise Level
 - Electronic Noise Level
 - “-50 dBu”?
- SNR
 - $10 \text{ dBu} - (-50 \text{ dBu}) = \mathbf{60 \text{ dB SNR}}$

30 dB << 60 dB! Hooray!

17

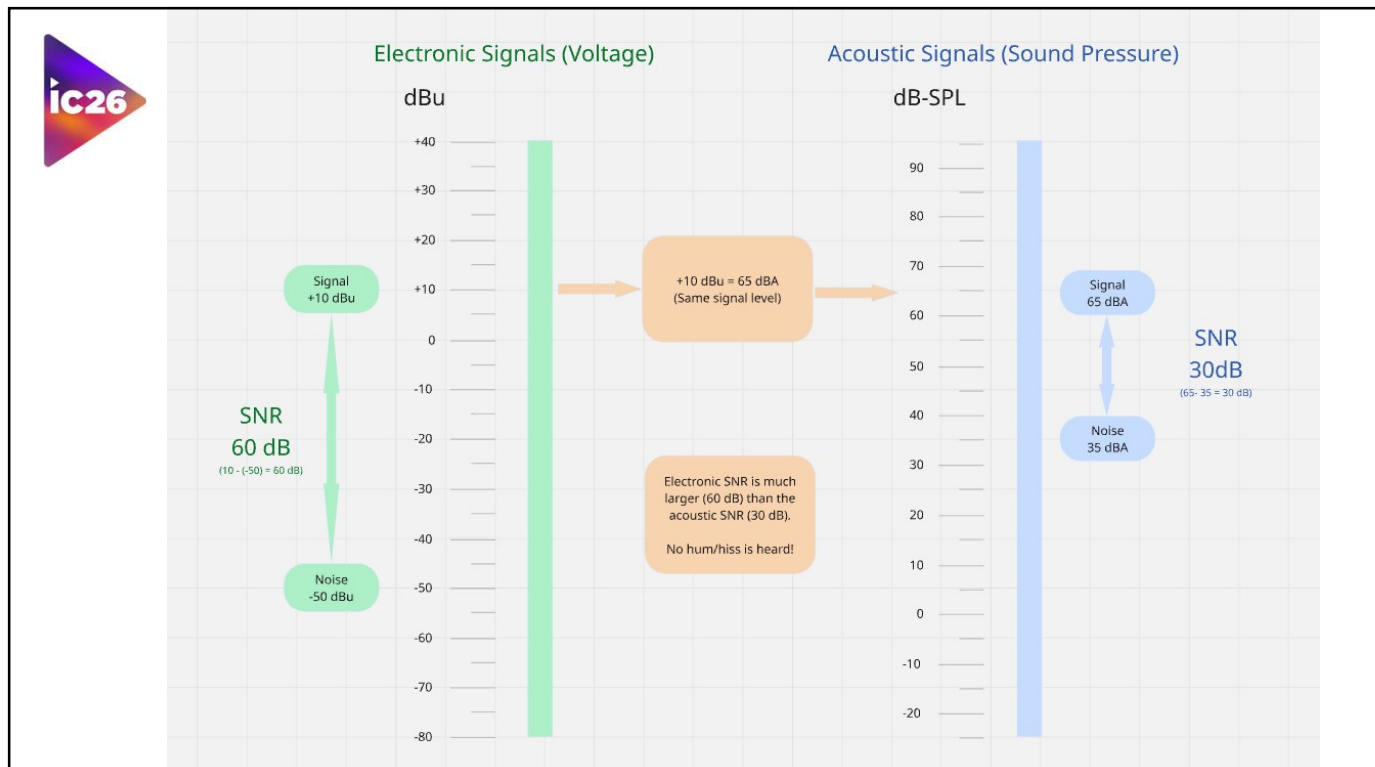

18



No distortion in signal

- Signal should pass through system without distorting the waveform
- Maximum voltage can be reaching with a loud talker or loud audio in playback material
- Need to verify signal at maximum expected voltage
 - Aka: Headroom Level

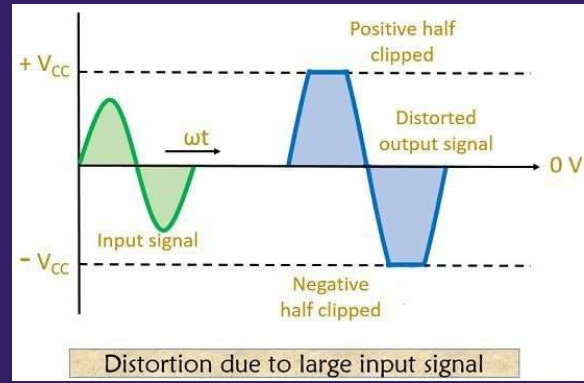

19

Distortion Demo

So fun!



20



Measuring THD

Measured at Headroom Level

- Max level system is designed for

Must use an electronic sine wave (tone)

- Signal generator must match headroom level signal

Should be less than 0.5%



21

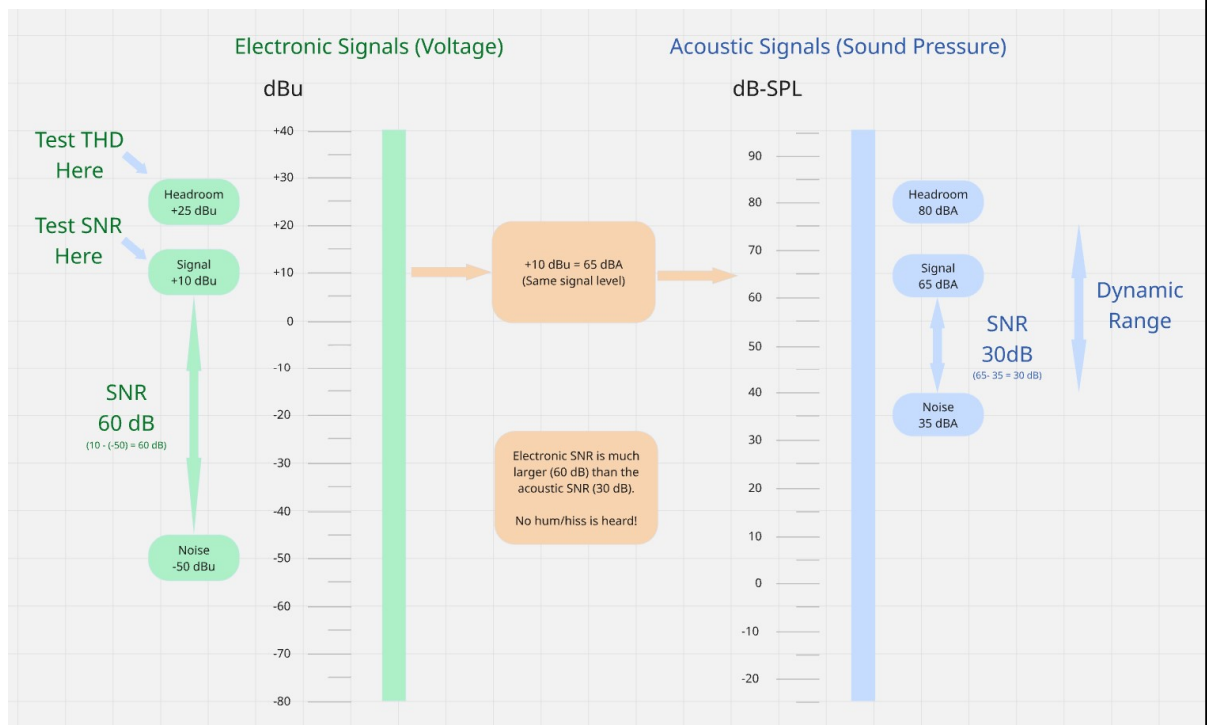

22

“Sounds great”, but how?

^^ See what I did there?



23



Assumptions for Today

- DSP Configuration was created per best practice
- Installation is complete
- The audio system is functioning and ready for “balancing”
- Acoustical dependencies have been delivered



24



PRE: Acoustic Measurements

Able to predict/ justify performance

Key metrics:

- NC
- RT60
- Ambient Noise
- SNR @ mic
- STC



25



Step 1: Confirm Physical Installation

Loudspeakers

- Location
- Taps
- Orientation

Microphones

- Location
- Orientation



26

ic26

Step 1+: Confirm Physical Installation

- Mic physical AND digital location are critical
- Be sure room graphic is scaled in software
- Be sure microphone placement in software matches physical placement in room
 - Talkers & Tables
 - Ceiling Height

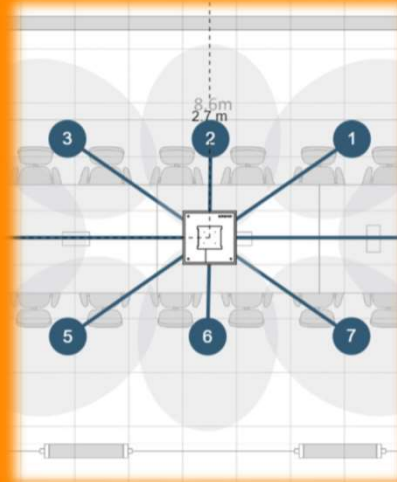

27

ic26

Step 2: Set Listen Levels

- Mixer output 0 dBu
 - “Unity gain”
- Pink Noise source
- Adjust amplifier until listen level is met (65 dBA)



28

ic26

Step 3: EQ Loudspeakers

- Pink noise source
- Adjust EQ to a relatively flat curve (or preferred)
- Parametric EQ may be easier

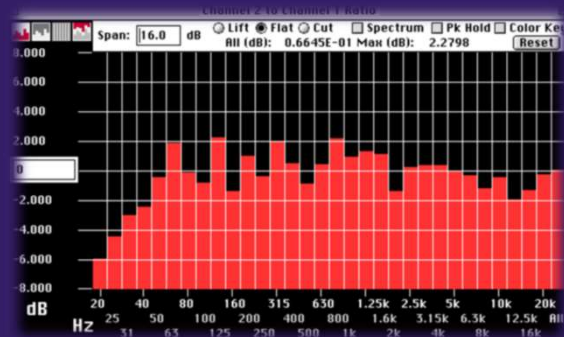

29

ic26

Step 4: Set Mic Levels

Use standard talker

- 60 dB-SPL @ 1m

Wired

- 0 dBu at mixer input

Wireless/Processor

- “Nominal” at receiver
- 0 dBu at mixer input



30



Step 5: EQ Microphones

- Roll off highs/low
- Ring out room to maximize stability
 - When applicable
- No more than 6 dB
 - Attenuate only
- Know when enough is enough

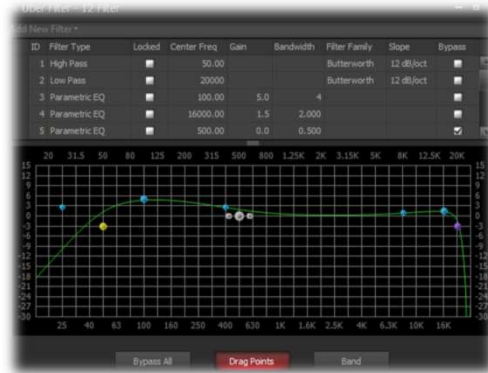

31



Step 6: Set Program Levels

- Nominal program source (-10 dBu)
- Pink noise is easiest
- Adjust input to achieve listen levels (60 dBA?)



32



Step 7: Conference Audio

- Tx = Rx = 0 dBu in mixer
- Rx distributed at listen levels
- Test for echo
- Test for double talk (full duplex operation)
- Use NLP and NR sparingly



33



Step 7+: AEC Reference

- AEC Ref = 0 dBu
- Must include all audio sources that need to be cancelled
 - Rx
 - Program
 - Other Rein. Mics
- Verify ERL/ERLE (and RMLR)



34

ic26

This is the big secret!

All levels set to "0 dBu"

- Mics
- Conference Rx
- Conference Tx
- AEC Reference

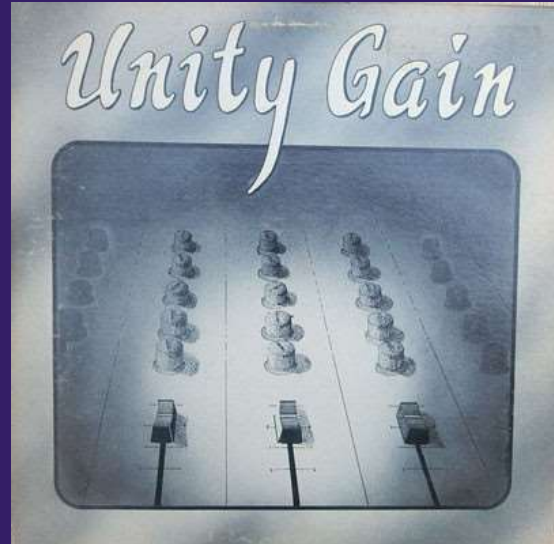

35

ic26

Why 0 dB?

- Comes down to signal to noise ratio
- Uber complex waveform in a multi-path environment
- DSP needs a robust signal without distortion to work with
- 0 dB is the answer
 - And it's easy to remember!

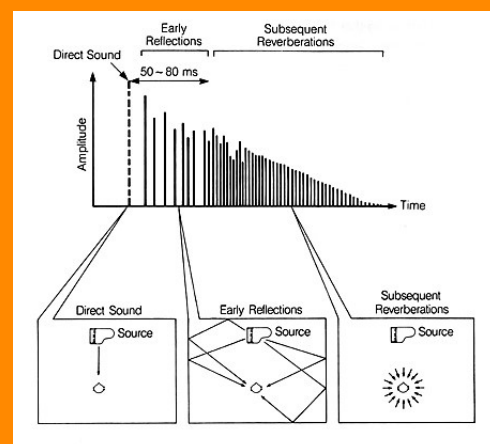

36



Step 8: Conf Program Audio

- Remember the program audio in conferencing
- Tx should be heard at program listen levels
- Rx should be heard at program listen levels



37



Step 9: Confirm All Presets

- DSP “gotcha”!
- Remember to re-test each preset
- Remember to save settings to each preset
 - Save it twice!
 - ...or three times



38



Step 10: Demonstrate

- Confirm operation
- Verify expectations were met



39



Still some art to it...

- SOP can get us 95% there in minutes
- Does not account for:
 - Difficult rooms
 - Challenging preferences
 - Unique solutions



40

ic26

Functionality is not enough!

Once we have the room “tuned”, we also need to verify the gain structure electronically:

- Verify listen levels
- Measure Acoustic SNR at Listen Level
- Measure Electronic SNR at Listen Level
- Measure THD at Headroom Level



41

ic26

Verify Listen Levels

Use SLM to measure listen levels

Confirm they meet requirements



42



Verify Acoustic SNR

Use SLM to measure ambient noise levels

Calculate SNR

Must be > 15 dB
(or 24 dB)



43



Verify Electronic SNR

- Use pink noise source
- Set up a standard talker
- Verify listen levels
- Measure signal voltage at amplifier output (dBu)
- Remove signal source
- Measure noise voltage at amplifier
- Calculate SNR
- Verify E-SNR \gg A-SNR

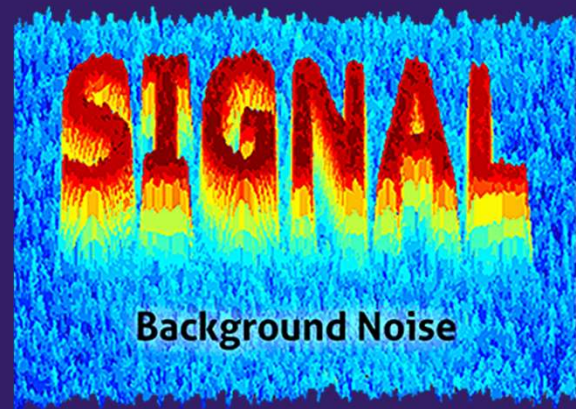

44



Verify THD

- Replace standard talker with signal generator
- Set generator to a tone at Headroom Level
- Match signal dBu level at amp and add headroom dB
- Measure THD of tone at Headroom Level
- Verify THD < 0.5%



45

So, now let's play!

...and now the real fun starts!



46



Demos

Simple gain structure
with analog mixer

Simple gain structure
with DSP

Installed sound vs. event
sound amplifier setting

- AKA: Let the amp sleep
vs. Set the amplifier at
11!

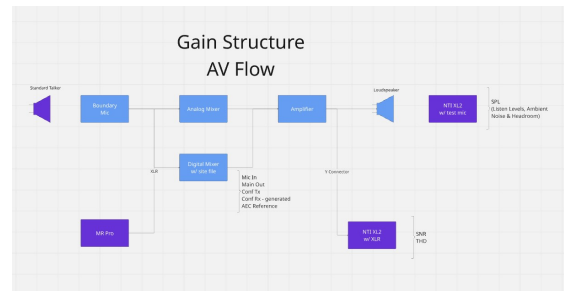

47



Demos

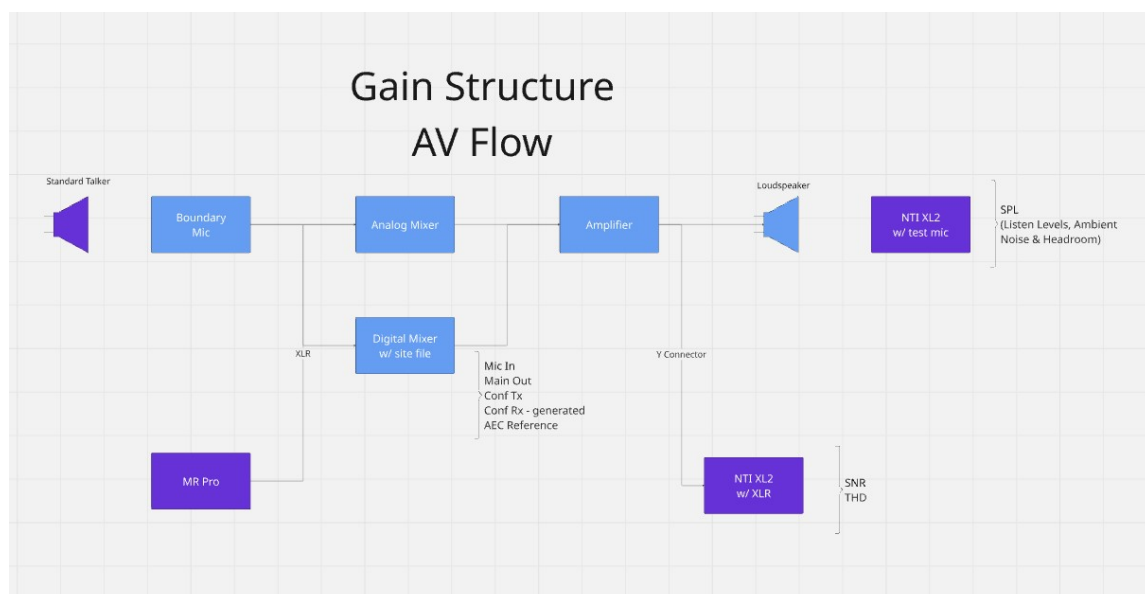

48

Questions? Discussion?

Reach out at:

jmaltese@L3AV.com

dandrewson@L3AV.com



49



We Value Your Feedback!

Please take a moment to complete the
session evaluation in the App

Thank you!

infocomm

50